

Inductive Sensors



Housing Style	Part Number	ID Number	Features	Sensing Range (mm)	Output
30 mm - Embeddable, eurofast® Connection 	Bi 15U-EM30-AN6X-H1141	M1636737	Uprox+, Stainless steel	15	3-Wire DC NPN
	Bi 15U-EM30WD-AN6X-H1141	M1634834	Uprox+, Washdown	15	
	Bi 15U-M30-AN6X-H1141	M1636736	Uprox+	15	
	Bi 15U-MT30-AN6X-H1141	M1636738	Uprox+, Teflon	15	
	Bi 15U-EM30-AP6X-H1141	M1636733	Uprox+, Stainless steel	15	3-Wire DC PNP
	Bi 15U-EM30WD-AP6X-H1141	M1634820	Uprox+, Washdown	15	
	Bi 15U-M30-AP6X-H1141	M1636732	Uprox+	15	
	Bi 15U-MT30-AP6X-H1141	M1636734	Uprox+, Teflon	15	
	Bi 15U-MT30-AP6X2-H1141	M1644741	Uprox+, Dual LED's	15	
	30 mm - Nonembeddable, eurofast Connection 	Ni 30U-EM30-AN6X-H1141	M1644636	Uprox+, Stainless steel	30
Ni 30U-EM30WD-AN6X-H1141		M1634832	Uprox+, Washdown	30	
Ni 30U-M30-AN6X-H1141		M1644635	Uprox+	30	
Ni 30U-MT30-AN6X-H1141		M1644637	Uprox+, Teflon	30	
Ni 30U-EM30-AP6X-H1141		M1646632	Uprox+, Stainless steel	30	3-Wire DC PNP
Ni 30U-EM30WD-AP6X-H1141		M1634822	Uprox+, Washdown	30	
Ni 30U-M30-AP6X-H1141		M1646631	Uprox+	30	
Ni 30U-MT30-AP6X-H1141		M1646633	Uprox+, Teflon	30	
Ni 30U-MT30-AP6X2-H1141		M1646635	Uprox+, Dual LED's	30	
30 mm - Embeddable, Potted-in Cable 		Bi 15U-EM30WD-AN6X	M1634843	Uprox+, Washdown	15
	Bi 15U-M30-AN6X	M1636735	Uprox+	15	
	Bi 15U-EM30WD-AP6X	M1634819	Uprox+, Washdown	15	3-Wire DC PNP
	Bi 15U-EM30-AP6X	M1636741	Uprox+	15	
	Bi 15U-M30-AP6X	M1636731	Uprox+	15	
	30 mm - Nonembeddable, Potted-in Cable 	Ni 30U-EM30WD-AN6X	M1634833	Uprox+, Washdown	30
Ni 30U-M30-AN6X		M1644634	Uprox+	30	
Ni 30U-EM30WD-AP6X		M1634821	Uprox+, Washdown	30	3-Wire DC PNP
Ni 30U-M30-AP6X		M1646630	Uprox+	30	



Voltage	Switching Freq. (Hz)	Operating Current (mA)	Operating Temp. (°C)	Protection	Housing	Face	Power LED	Output LED	Mating Cordset	Wiring Diagram #	Wiring Diagrams
10-30 VDC	750	≤200	-25 to +75	IP 68	SS	LCP	N/A	YE	RK 4T-*	1	Diagram 1
	750	≤200	0 to +85	IP 68, 69K	SS	LCP	N/A	YE	RK 4T-*	1	
	750	≤200	-25 to +75	IP 68	CPB	LCP	N/A	YE	RK 4T-*	1	
	750	≤200	-25 to +75	IP 68	TC	LCP	N/A	YE	RK 4T-*	1	
10-30 VDC	750	≤200	-25 to +75	IP 68	SS	LCP	N/A	YE	RK 4T-*	2	Diagram 2
	750	≤200	0 to +85	IP 68, 69K	SS	LCP	N/A	YE	RK 4T-*	2	
	750	≤200	-25 to +75	IP 68	CPB	LCP	N/A	YE	RK 4T-*	2	
	750	≤200	-25 to +75	IP 68	TC	LCP	N/A	YE	RK 4T-*	2	
	750	≤200	-25 to +75	IP 68	TC	LCP	GN	YE	RK 4T-*	2	
10-30 VDC	500	≤200	-25 to +75	IP 68	SS	LCP	N/A	YE	RK 4T-*	1	Diagram 3
	500	≤200	0 to +85	IP 68, 69K	SS	LCP	N/A	YE	RK 4T-*	1	
	500	≤200	-25 to +75	IP 68	CPB	LCP	N/A	YE	RK 4T-*	1	
	500	≤200	-25 to +75	IP 68	TC	LCP	N/A	YE	RK 4T-*	1	
10-30 VDC	500	≤200	-25 to +75	IP 68	SS	LCP	N/A	YE	RK 4T-*	2	Diagram 4
	500	≤200	0 to +85	IP 68, 69K	SS	LCP	N/A	YE	RK 4T-*	2	
	500	≤200	-25 to +75	IP 68	CPB	LCP	N/A	YE	RK 4T-*	2	
	500	≤200	-25 to +75	IP 68	TC	LCP	N/A	YE	RK 4T-*	2	
	500	≤200	-25 to +75	IP 68	TC	LCP	GN	YE	RK 4T-*	2	
10-30 VDC	750	≤200	0 to +85	IP 68, 69K	SS	LCP	N/A	YE	2M/PUR	3	
	750	≤200	-25 to +75	IP 68	CPB	LCP	N/A	YE	2M/PVC	3	
10-30 VDC	750	≤200	0 to +85	IP 68, 69K	SS	LCP	N/A	YE	2M/PUR	4	
	750	≤200	-25 to +75	IP 68	SS	LCP	N/A	YE	2M/PUR	4	
	750	≤200	-25 to +75	IP 68	CPB	LCP	N/A	YE	2M/PVC	4	
10-30 VDC	500	≤200	0 to +85	IP 68, 69K	SS	LCP	N/A	YE	2M/PUR	3	
	500	≤200	-25 to +75	IP 68	CPB	LCP	N/A	YE	2M/PVC	3	
10-30 VDC	500	≤200	0 to +85	IP 68, 69K	SS	LCP	N/A	YE	2M/PUR	4	
	500	≤200	-25 to +75	IP 68	CPB	LCP	N/A	YE	2M/PVC	4	

Uprox+

* Length in meters.

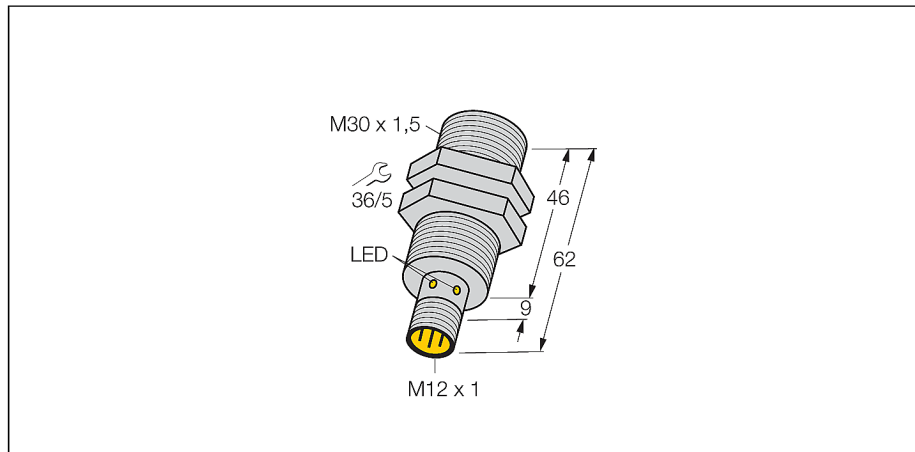

- threaded barrel, M30 x 1.5
- Chrome-plated brass
- factor 1 for all metals
- degree of protection IP68
- magnetic field immune
- high switching distance
- recessed mounting possible
- 3-wire DC, 10...30 VDC
- normally open, pnp output
- connector, M12 x 1

Wiring diagram

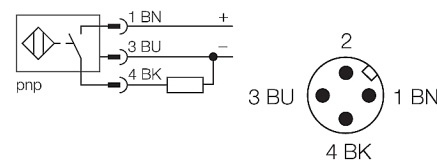

Functional principle

Inductive sensors are designed for wear-free and non-contact detection of metal objects. uprox+ sensors have considerable advantages due to their patented multi-coil system. They excel in highest switching distances, maximum flexibility and operational reliability as well as efficient standardisation.

Type	Bi15U-M30-AP6X-H1141
Ident-No.	1636732
Rated operating distance Sn	15 mm
Mounting condition	flush
Assured sensing range	≤ (0,81 x Sn) mm
Temperature drift	≤ ± 10 %
Hysteresis	≤ ± 15 %, ≤ -25 °C v ≥ +70 °C
Repeatability	3... 15 %
Ambient temperature	≤ 2 %
	-30...+ 85°C
Operating voltage	10... 30VDC
Residual ripple	≤ 10 % U _{SS}
DC rated operational current	≤ 200 mA
No-load current I ₀	≤ 15 mA
Residual current	≤ 0.1 mA
Rated insulation voltage	≤ 0.5 kV
Short-circuit protection	yes / cyclic
Voltage drop at I _e	≤ 1.8V
Wire breakage / Reverse polarity protection	yes / complete
Output function	3-wire, normally open, pnp
Insulation class	□
Switching frequency	≤ 0.75 kHz
Housing	threaded barrel, M30 x 1.5
Dimensions	62 x 30 mm
Housing material	metal, CuZn, chrome-plated
Material active face	plastic, LCP-GF30
Tightening torque of housing nut	75 Nm
Connection	connectors, M12 x 1
Vibration resistance	55 Hz (1 mm)
Shock resistance	30g (11 ms)
Degree of protection	IP68
Display switch state	LED yellow